

UTSK | UTSP visio

180 - 900 kW

THE TOUGH SMALL ONE

Underfeed combustion system UTSK | UTSP visio

Heat exchanger design

- 3-pass fire tube
- Warm water up to 6 bar / 110°C
- Hot water up to 6 bar / 120°C

Fuel water content

M 10 - 50

Nominal capacity up to fuel water content

M 45

Thermal insulation of the combustion chamber

100 mm

Grate cooling

Air

Capacity control

Modulating

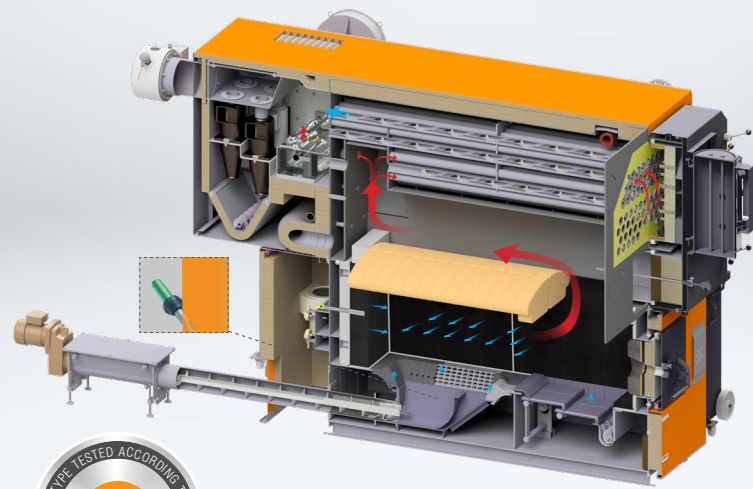

TECHNICAL DETAILS

Type	Nominal capacity 30-100 % [kW]	Furnace rating [kW/m ³]	Primary air zones	Total weight w/o water [kg]	Heat exchanger water content [l]	Heat exchanger heating surface [m ²]
UTSK/P-180	54 - 180	560	2	4765	645	17
UTSK/P-240	72 - 240	745	2	4765	645	17
UTSK/P-300	90 - 300	550	2	5600	855	21
UTSK/P-360	108 - 360	650	2	5600	855	21
UTSK/P-450	135 - 450	530	2	7500	1315	31
UTSK/P-500	150 - 500	588	2	7500	1315	31
UTSK/P-550	165 - 550	650	2	7500	1315	31
UTSK/P-700	210 - 700	650	2	8285	2355	59
UTSK/P-900	270 - 900	830	2	8285	2355	59

Technical changes and printing errors reserved.

Wood chips



Wood pellets



Residual wood



Sawdust



Shavings



Long lasting firing system
for industrial applications

Designed for year round
operating

Highest efficiency, highest
safety, best emissions

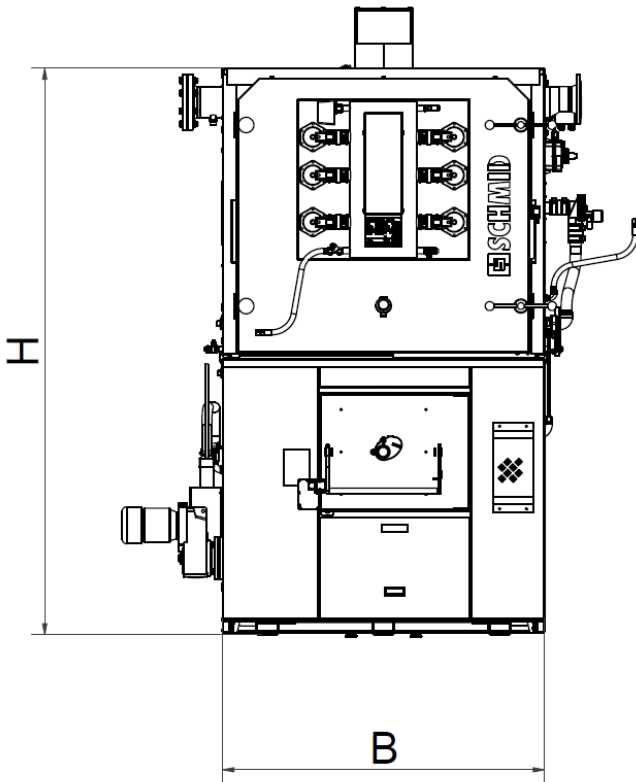

Type	L = Length [mm]	B = Width [mm]	H = Height [mm]
UTSK/P-180	3275	1150	2290
UTSK/P-240	3275	1150	2290
UTSK/P-300	3495	1250	2340
UTSK/P-360	3495	1250	2340
UTSK/P-450	4005	1440	2540
UTSK/P-500	4005	1440	2540
UTSK/P-550	4005	1440	2540
UTSK/P-700	4625	1600	3090
UTSK/P-900	4625	1600	3090

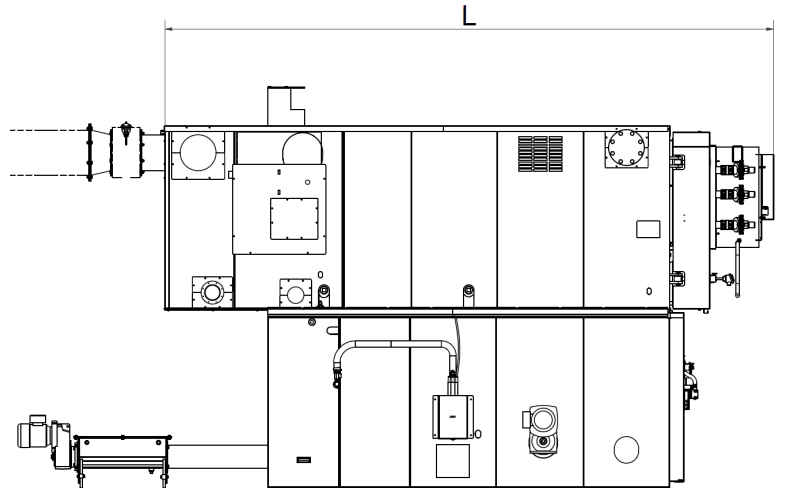

SCHMID AG, ENERGY SOLUTIONS

WWW.SCHMID-ENERGY.CH

SCHMID
energy solutions

Technical changes and printing errors reserved.